

CASE STUDY FOR FRE<sup>®</sup>  
**UNDERWATER**  
CONDUITS

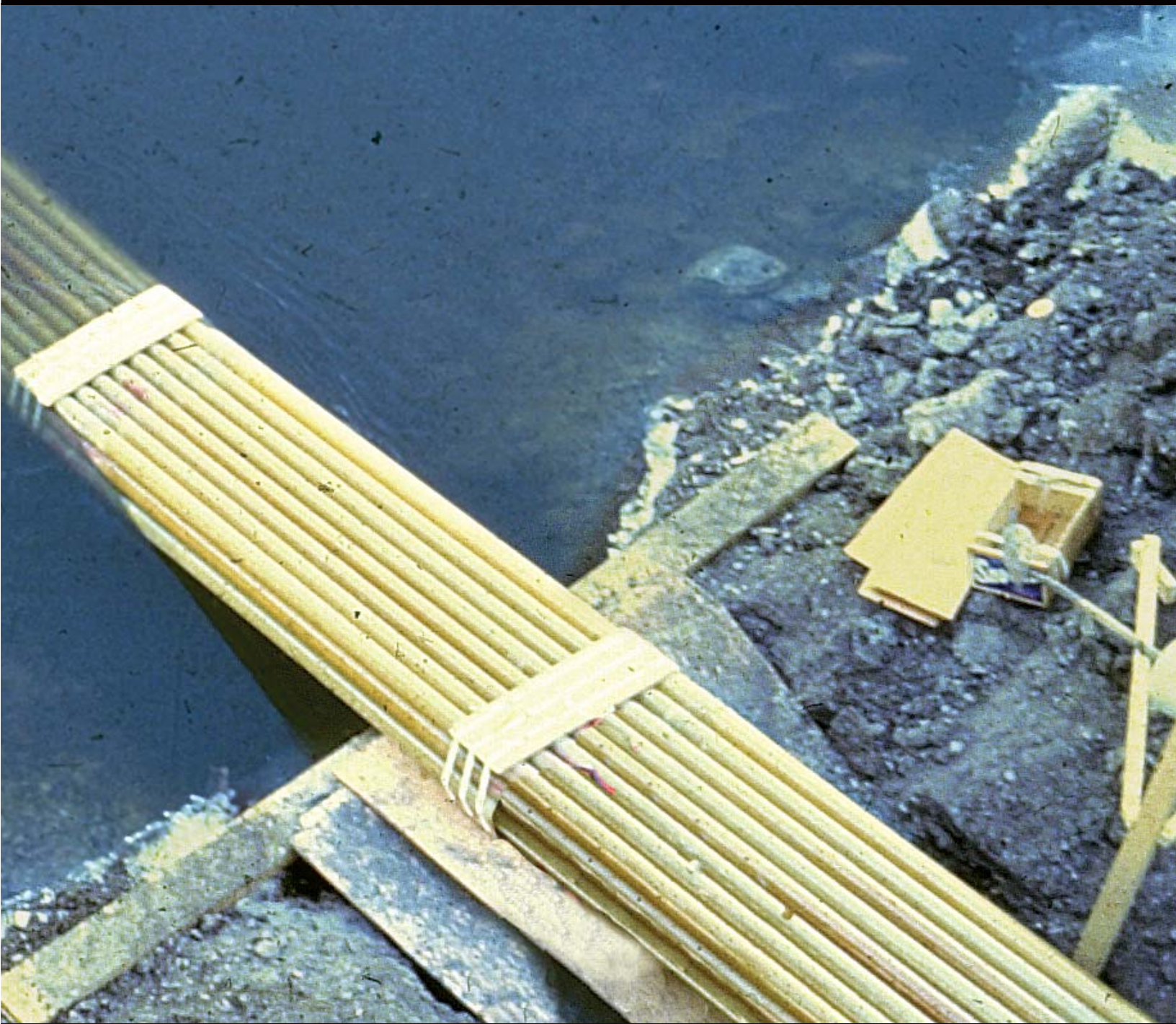

**FRE**  
COMPOSITES<sup>®</sup>

F I R S T I N T H E F I E L D

®

---

## Case study

### Underwater crossing of Richelieu river

---

#### Editor's note

A report was issued by Hydro-Québec on November 20<sup>th</sup>, 1980 which detailed that utility's experience with FRE<sup>®</sup> Underwater Conduit System for river crossings. This document deals with the underwater crossing of the Richelieu River in Saint-Jean-sur-le-Richelieu (Quebec, Canada). This summary was translated as accurately as possible from the original French transcript issued by Hydro-Québec as report no. 30880080-09.

This document was not intended to show the ideal nor the simplest application for FRE<sup>®</sup> Underwater conduit System. Rather, it was meant as a summary of the actual events which took place at the Richelieu River crossing and its results.



---

## Table of Content

### Underwater crossing of Richelieu River

---

<b>OBJECT OF PROJECT</b>	<b>6</b>
<b>RECOMMENDED SOLUTIONS</b>	<b>6</b>
CONDUITS ATTACHED TO THE BRIDGE	6
AERIAL CROSSING	6
SUBMARINE CABLE	6
PRE-FABRICATED NETWORK	7
BURIED NETWORK	7
<b>THE ADOPTED SOLUTION</b>	<b>7</b>
CHOICE OF SITE	7
DRILLING AND RIVER PROFILE	7
REQUESTED AUTHORIZATION	8
<b>TRENCH EXCAVATION</b>	<b>8</b>
EXCAVATION ON SHORES	8
EXCAVATION UNDER WATER	8
CHOICE OF CONDUIT TYPES	9
CONDUIT ASSEMBLY	9
ASSEMBLING CONDUIT RUN IN THE STREET	10
CONDUIT PULL	10
CONCRETE POURING	11
FILLING UP	12
RODDING	12
CABLE PULLING	12
<b>CONCLUSION</b>	<b>12</b>
<b>APPENDIX</b>	<b>13</b>
INSTRUCTIONS FOR UNDERWATER CROSSING WITH FRE® CONDUIT	13

---

## Underwater Crossing of Richelieu River

---

### Object of Project

---

The increase in the peak load east of the Richelieu River necessitated an additional power source for the 1979-80 peak. Various possibilities were looked at. A study of the equipment program for the next ten (10) years showed the advantage of a network with multiple conduits in the Richelieu. Furthermore, multiple conduits would permit a possible delay of the Rouville Station - 230-250 kV (which occurred afterward) and postponement of the Beloeil Station - 230-250 kV for at least two (2) more years. Other savings and sharing of future loads made the recommended solution even more attractive. The planned maximum use of the conduit back was for six (6) feeders.

### Recommended solutions

---

Various alternatives were considered in the planification study and compared over a period of ten (10) years.

#### ***Conduits attached to the bridge***

This solution was rejected because the two (2) bridges swivel part of their deck for boat crossings. The only bridge with a fixed deck in the surroundings is one on Autoroute 20 which is too far from the concerned zone.

#### ***Aerial Crossing***

The construction of an aerial crossing required the erection of towers on each shore, high enough to give a 32.8 ft. or 10 m clearance over the river. Each tower would have had to support two (2) distribution lines. The restriction on installing such structures in urban areas would necessitate an underground installation on each side of the river for approximately 2.5 miles or 4 km, which would have been a prohibitive project even if it would have been spread over several years.

#### ***Submarine Cable***

Laying of submarine cable in the river was considered. Six (6) cables were to be installed over a period of years as per the network needs. After evaluation of the costs due to the non-availability of material to complete the project for the 1979-80 peak and inherent dangers to the crossing, this solution was eliminated. The water way serves as a boat waiting space for the Canadian National Railroad Bridge opening and breakage risks due to anchors were judged high. Cable-laying in trenches was a prohibitive project because it would have had to be repeated many times.

### ***Pre-fabricated network***

The use of a pre-fabricated network was not appropriate in this case due to the notable depth of the river. Furthermore, the experience in May 1979 done at the regional office showed a lack of watertightness of these networks resulting in water and sand infiltration. This solution was disregarded.

### ***Buried network***

The use of a buried network under the river bed presented certain advantages. It permitted the addition and replacement of cables inside the network very easily and at any time. The breakage risk by boat anchoring was eliminated as well because the concrete would be deeply buried and covered with earth.

## **The Adopted Solution**

---

The adopted solution consists of building a bank of eight (8) FRE® conduits in concrete, buried under the river bed. To the six (6) requested conduits, it was necessary to add one spare and another one was added to obtain a rectangular configuration as well as for an eventual utilization for communications. The installation method consisted in pre-assembling an eight (8) conduit unit on the river bank, pulling it into the specified trench and covering it with concrete and the excavated earth fill.

### ***Choice of site***

The site was chosen by considering the immediate needs of feeding loads and the future needs of interconnection between the Hydro Québec's power stations of Rouville and Beloeil. Because the river channel is used for navigation, no place is suitable for an underwater conduit bank crossing within 0.9 miles or 1.5 km downstream of the chosen site. Up stream, we are further off the direct line between the two (2) stations and conditions remain approximately the same with less facility and access to the shores.

### ***Drilling and River profile***

At the chosen site, the navigation charts indicated a 23 ft. or 7 m depth over a very large area. To ensure a successful installation, a more detailed plan was necessary. In February 1979, the river profile was obtained by piercing holes in the ice where a metallic wire with a weight attached was lowered down. These holes were spaced 26.2 ft. or 8 m apart and the resulting profile indicates the maximum depth at 29.5 ft. or 9 m. On the McMasterville side, the slope of the river bed is of 11°, whereas on the Otterburn Park side, it is only 4°.

To better understand the type of soil to be excavated and to determine the rock depth, we made one test boring on each shore and two (2) in the river bed, one of these being at the deepest spot. For the borings in the river bed, we used a drilling machine mounted on a raft stabilized by four (4) anchors. These results indicate that the excavation will be made in a silt type sand having penetration index between approximately twenty (20) and thirty five (35), i.e. fluctuating from consistent to dense. Drilling #2 and #3 virtually guaranteed a covering of approximately 5.7 ft. or 1.75 m over the rock thereby avoiding the use of dynamite.

### ***Requested Authorization***

To realize such a project requires many authorizations such as:

- approval of the concerned municipalities
- an authorization from the Quebec Natural Resources Department
- a right of way from the Quebec Forestry Department
- acquisition of an exemption notice issued by Transport Canada
- an authorization certificate issued by Environment Québec

The crossing of eight (8) conduits under the river bed requires digging out a trench which involves the disturbance and dispersion of sediments in the river bottom. This created the possibility of freeing toxic substances from the sediment which would hamper the acquisition of the necessary certificates. This possibility was considered likely because of the C.I.L Company plant situated up-stream of the chose site. Furthermore, to reduce the costs of such a project, it was preferable to obtain authorization to deposit the excavation material downstream of the trench instead of taking them out of the river.

From samples picked up in the river bed, the Environment Department made a study which showed that the aquatic ecosystem would not be disturbed by the work to be done.

### **Trench Excavation**

---

The trench excavation was made, i.e. from manhole #1 situated in McMasterville to manhole #2 Otterburn Park. The run between the two (2) manholes covers a distance of 1,024 ft. or 312 m of which 755 ft. or 230 m are under water.

#### ***Excavation on shores***

The excavation was executed normally except near the approach to manhole # 1. As to not stop traffic on Road # 223 during the pulling of the conduit structure, it was necessary to install a 30 in. or 760 mm diameter conduit under this road.

#### ***Excavation under water***

A hydraulic crane with a nine hundred and sixty (960) liter capacity (1 ¼ cubic yard) bucket mounted on a barge was used to dig the trench. The crane reach was 52.5 ft. or 16 m. The displacement of the barge was done with the help of four (4) steel cables tied up-stream and downstream and fixed to a complex winch system located on the platform. These independent cables facilitated barge alignment with designated guide marks on the shore. Finally, the installation of two (2) pillars in the river bed produced very good stability. A relocation of this platform was necessary after every 19.68 ft. or 6 m of excavation.

The trench dimensions are 3.6 ft. or 1.1 m deep and point 2.8 ft. or 0.85 m wide with 45° walls. The excavation materials were put downstream. The trench depth was verified with a marked chain to which a weight was attached.

This way of proceeding gave us a rectilinear trench with a flat bottom.

The excavation required eleven (11) days, double the forecasted time. The reason for this was a silty sand, extremely dense between the hundred (100) and two-hundred sixty (260) markers which prevented the shovel from working effectively.

This document is the property of FRE Composites (2005) Inc. It shall not be used, reproduced, copied or transmitted to other persons without written authorization from FRE Composites (2005) Inc. - © 2005. All rights reserved, FRE Composites (2005) Inc.

### ***Choice of conduit types***

The only conduits that met the weight requirements, strength and low coefficient of friction were FRE®'s. These conduits were supplied by FRE Composites and manufactured at their Saint-Andre-d'Argenteuil plant.

Conduit specifications:

- helical structure
- sections length: 39.4 ft. or 12 m (2 sections of 19.68 ft. or 6 m connected and wrapped)
- inside diameter: 4.5 in. or 115 mm
- wall thickness: 0.1 in. or 2.5 mm
- weight per length unit: 1.21 lb./ft. or 1.8 kg/m
- density: 1.84

### ***Conduit assembly***

The conduit assembly was done by joining the 39.4 ft. or 12 m sections together as per the manufacturers recommended method.

A 86°F or 30°C temperature was necessary for the drying of the epoxy resin with the joints manufactured under shelter. First, 118.1 ft. or 36 m sections were assembled and then the complete run was built from these sections.

Joints were assembled and glued as follows:

- 1) Conduits were joined together and forced in with a hammer.
- 2) At the conduit joints, the addition of a resinous coating gave a more uniform external surface transition.
- 3) To cure this coating, a temperature of 86°F or 30°C for five (5) minutes was required.
- 4) The cured coating as well as the glazed surrounding surfaces were then lightly sanded to obtain a uniform and adherent finish.
- 5) Three (3) fiberglass cloths of 5.9 in. x 18.1 in. or 150 x 460 mm were applied with a stagger of approximately 2 in. or 50 mm between them. Each cloth was liberally coated with an epoxy resin mixed with a curing product. To complete the assembly roll these coated cloths around the conduit, being careful to maintain the tension on these cloths during the application. Air pockets that could remain trapped between the cloths and the conduit were forced out with the roller supplied.
- 6) The curing was complete with a curing period of thirty (30) minutes at 86°F or 30°C. As per the supplier, the axial tensile strength at the joint was equal or superior to the conduit itself. (12.5 kN).

### ***Assembling conduit run in the street***

Using the same technique described above, the 118 ft. or 36 m sections were joined together. As the final assembly had to be rectilinear and perpendicular to the river, the middle of the street was used to make the assembly. Conduits were placed in a configuration of two (2) conduits high by four (4) wide. Spacers of 2 in. or 50 mm were installed at every 4.9 ft. or 1.5 m. As to assure the final structure solidity, without increasing the weight, we used alternatively a concrete spacer and a plastic one. We circled the



structure with metallic bands of 1 in. x 0.04 in. or 25 mm x 1 mm on each side of the spacer to stabilize it. The time required to make the assembly was ten (10) working days.

### ***Conduit pull***

The pulling of the conduit assembly into the trench at the bottom of the river represented the most critical phase of the entire installation. All factors were calculated and considered: the conduit tensions, material density, lines of slope and a safe coefficient of friction. The principle data are:

- total length of conduit run: 1024 ft. or 312 m
- total weight of conduit assembly: 9 921 lb. or 4 500 kg
- weight of pulling sled: 496 lb. or 225 kg
- maximum tension allowed by conduit: 12 500 N
- river width: 755 ft. or 230 m

So as to minimize rubbing between the conduit assembly and the ground, the assembly was laid on rollers spaced 19.68 ft. or six 6 m apart.

At the head end of the assembly, each conduit was equipped with a pulling head previously installed by the supplier. Each head had four (4) holes of 0.8 in. or 20 mm diameter which allowed for water infiltration into the conduits and consequent submersion as the structure was pulled into the river.

In the first pulling stage, the assembly was pulled a distance of 98.4 ft. or 30 m, crossing under road # 223 and up to the shore. The heads were fixed to a cable and tied to a winch which was manually operated.

At the second pulling stage, the pulling heads were attached to the sled. To equally distribute the tension among the conduits, a steel cable was attached to each pulling head in sequence and was anchored on each side of the sled shaft.

The shaft was constructed so as to rotate relative to the sled and hence responded well to slope and angle variations in the trench. This eased the pulling loads while evenly distributing the tension to the conduits. The sled weight of 498 lb. or 226 kg was selected to ensure it laid at the bottom of the trench during the pulling based on the forces known to be present.

The pulling was done from McMasterville to Otterburn Park. A diver watched the process during pulling and verified that the assembly remained at the bottom of the trench. The pulling took approximately one hour and went as expected. To determine the pulling tensions, a recording system was installed. The dynamometer with a precision of 1% was rated from 1 to 90 KN. Tensions were recorded on graphic tapes.

The recording represents the plot of the pulling load from the time the conduits entered the river till they emerged. The abscissa of the recording is the time-in minutes and the ordinate the  $F^2$  strength in newtons. We obtained the zero calibration of the recording devices by eliminating all tension on the load cell.

The pulling lasted approximately one (1) hour. The only difference between these two (2) sections is the speed of the chart paper, i.e. 5.28 ft./hr or 160 cm/hr for II and 1.98 ft./hr or 60 cm/hr for III. The average pulling load varies from seven thousand (7,000) to ten thousand (10,000) newtons.

It is difficult to establish a precise correlation between the elapsed time and distance covered due to the pulling speed irregularities and the many stops. Therefore, we carefully marked the conduits at 164 ft. or 50 m intervals and indicated on the recording plot at what time these sections entered the river.

Between the 25<sup>th</sup> and 28<sup>th</sup> pulling minutes, we registered a very high tension which went from nine thousand five hundred (9,500) to thirty one thousand (31,000) newtons in 1 minute. It seems that this pull variation could be associated with the fact that the sled and conduits scraped one side of the trench and were almost pulled out. This information was confirmed by the diver who was monitoring the underwater activities. He noted that as this point the trench was slightly curved to the downstream side.

The tension is lower at the beginning of the pull than at the end because initially the conduits slide on rollers before going into the water and the trench has a slight slope, i.e. eleven (11) and four (4) degrees for the downward and the upward shores of the run. Furthermore, we must take into consideration the suction force that a sandy and slightly muddy bottom could product. Note that the weak current of 3.73 to 4.97 miles/hr or 6 to 8 km/hour had no perceptible effect on the pull.

The average pulling tension for the 4 500 kg of the sleigh and conduits is seven thousand (7,000) to ten thousand (10,000) newtons, disregarding the surge points that occurred half way. This represents less than 10% of the maximal strength allowed per conduit.

### ***Concrete pouring***

Concrete was used for the first stage of backfilling. In this way, we eliminate all risks of sand infiltration inside the conduits following a cable break, an anchoring or a river dragging. This also makes the formed conduit bank more rigid and prevents the conduit heaving during cable pulling and water draining. As calculated, a 9.8 in. or 250 mm concrete coating around the structure is appropriate. Concrete with twenty (20) MPA capacity was used made up of 0-04. in. or 0-10 mm stones and with a higher cement content than standard so as to facilitate pumping.

The concrete was poured from the center of the river towards the shores so as to let the conduit expand towards the shores. To facilitate this, a pier was installed perpendicular to the shore and extending two third (2/3) of the width across. The pouring was done in two (2) steps: first, from center toward one shore, then by displacing the pier and all the equipment to the other side the remainder was poured. Concrete was pumped and channeled to the bottom of the river with a 3.9 in. or 100 mm diameter pipe. Going progressively towards the shore meant removing sections as directing that pipe and by radio, was controlling operations of the crane mounted on the barge. The diver was carefully keeping the end of the pipe in poured concrete to avoid concrete dilution with water. The principle is to preserve the concrete homogeneity.

The concrete thickness was constantly verified by the divers who confirmed that concrete was easily penetrating between the conduits. The concrete application lasted two (2) days and 3 227.52 ft.<sup>2</sup> or 300 m<sup>2</sup> of concrete were poured which included the shore accesses.

### ***Filling up***

Twenty four (24) hours after the concrete installation, the trench was filled up with material left downstream at the time of excavation. This operation was done with the same technique as used for excavation. As per Transport Canada requirements, this filling up was necessary

in order to make the river bed uniform. Furthermore, better protection for the conduit bank was obtained.

**Roding**

To facilitate roding, a polyethylene rope was inserted in each conduit at time of assembly. We then tied to each rope a wooden mandrel of 3.9 in. or 100 mm diameter to which a second polyethylene rope was attached for cable pulling. Roding of each conduit was done manually so as to verify its condition. No obstruction was encountered.

**Cable Pulling**

The total distance between the two (2) manholes was measured at 1 024 ft. or 312 m. Two (2) 750 MCM Al twisted cables, with cross link insulation and concentric neutral in tinned copper were pulled. A pulling eye had been previously installed to face any eventualities. Each cable was pulled into a conduit filled with water with measured. The maximum tension was only 4 888 KN i.e. approximately 59% of the anticipated tension for such a distance in a dry conduit.

**Conclusion**

---

The total duration of civil works lasted a month with total costs of Two hundred thousands dollars (\$200,000). To cover a 755 ft. or 230 m distance underwater and 269 ft. or 82 m on shores, the costs\* are as follows:

1) Duck bank in the river bed and on shores (contract)	\$ 140,000
2) Purchased of FRE® conduit	\$ 26,000
3) Laboratory, divers and drilling	\$ 16,000
4) Administration	\$ 18,000

\*Cost incurred in 1979-80

Taking into consideration the magnitude of this project and the results obtained, this cost is very reasonable and comes Fifty thousand dollars (50,000\$) below the original estimate.

It must be emphasized that during the working period we were not faced with any problems. The measured tension on the conduits during pulling was weaker than that permitted, we could than accomplish longer distances with this type of conduit than was thought possible. The maximum available length of H.V. cables sets the distance limit. The instructions given by FRE Composites were proved exact and no problems were encountered. The use of the FRE® conduit which combined flexibility with a high axial strength gave a final product superior to a standard conduit bank. The Richelieu River obstacle which we were confronted with in order to supply economical load distribution is therefore eliminated.

This document is the property of FRE Composites (2005) Inc. It shall not be used, reproduced, copied or transmitted to other persons without written authorization from FRE Composites (2005) Inc. - © 2005. All rights reserved, FRE Composites (2005) Inc.



## APPENDIX

---

### *Instructions for Underwater Crossing with FRE® conduit*

## APPENDIX "A"

### **SOLVING THE BUOYANCE PROBLEM**

During the installation of river crossing conduit, the conduit must be flooded to ensure that it will stay in the trench. After installation sufficient backfill must be placed on top of the conduit to ensure that the conduit will not float out of the trench when by some coincidence all of the water is blown out of all the conduit such that the entire conduit bank is air filled and without cables in place.

The buoyancy of the conduit is based on the weight of the water displaced by the conduit minus the weight of the conduit. Sufficient backfill must be used to cover the conduit such that the weight of this backfill in the water is greater than the buoyancy effect of the conduit.

The following equation can be used to calculate the volume of solid material for various types of soil. According to Spangler, Second Edition "Soil Engineering" , the usual range of true specific gravity values for soils is between 2.55 and 2.75. This is due to the law of averages and the normal preponderance of quartz and quartz-like minerals in soil which have a specific gravity of about 2.65. In order to be conservative we have used the value of 2.55 for true specific gravity.

		$V$	=	Volume of solid particles
$V$	=	$\frac{W}{\mu G}$		$\mu$
				=
				Unit weight of water (62.4 lb./ft <sup>3</sup> or 999.5 kg/m <sup>3</sup> )
				$G$
				=
				True specific gravity (use 2.55)
				$W$
				=
				Dry weight of soil

The values for the dry "weight of soil shown in the following table was taken from "The Handbook of Steel Drainage & Highway Construction Products" published by the American Iron and Steel Institute.

Maximum unit dry weight in lb./ft<sup>3</sup>.

- Silts and clays	65	--	105	(use 65)
- Sand and sandy soil	100	--	130	(use 100)
- Gravel and gravelly soils	115	--	135	(use 115)

(from page 216 of the above mentioned Handbook)

This document is the property of FRE Composites (2005) Inc. It shall not be used, reproduced, copied or transmitted to other persons without written authorization from FRE Composites (2005) Inc. - © 2005. All rights reserved, FRE Composites (2005) Inc.

In the above table the lower value for each soil type was used so that the resulting answers would be somewhat conservative.

Each duct needs to be buried under a volume  $V$  of backfill whose weight  $W$  will hold the duct submerged by overcoming its natural tendency to float. That volume is defined as  $L \times D \times d$ , where  $L$  is the unit length of duct,  $D$  is the unit depth of backfill and  $d$  is the external diameter of the duct. If  $v$  is the void fraction of the backfill used, we have:

$$v = 1 - d_{app}/d_{true}$$

where  $d_{app}$  and  $d_{true}$  are the apparent and true densities of the backfill

$d_{true}$  is assumed to be equal to 159.12 lb/ft<sup>3</sup> or 2549 kg/m<sup>3</sup> for all quartz-like minerals

$d_{app} = 65 \text{ lb / ft}^3$  or 1041 kg/m<sup>3</sup> for silt and clay backfills

$d_{app} = 100 \text{ lb / ft}^3$  or 1602 kg/m<sup>3</sup> for sand and sandy soils

$d_{app} = 115 \text{ lb / ft}^3$  or 1842 kg/m<sup>3</sup> for gravel and gravelly soils

$$W = ((1 - v) \times 159.12 \times V) - ((1 - v) \times 62.4 \times V)$$

where the first term is the true weight of the backfill and the second term is the buoyancy of the backfill (the weight of the volume of water it displaces)

therefore  $W = (1 - v) \times (159.12 - 62.4) \times V$

thus  $W = (1 - v) \times (96.72) \times L \times D \times d$

where 96.72 is the density differential between backfill and water

and finally  $W = (1 - v) \times (96.72) \times d$

where  $d$  is expressed in feet or meter (for a unit backfill depth of 1 ft or 0.3 m and a unit conduit length of 1 ft or 0.3 m)

The above equation and data were used to obtain the minimum depth of cover required for a conduit bank as shown in the following summary:

Conduit Size In.	Minimum Wt. of the Duct lb./ft.	Weight of Water displaced by the duct lb./ft.	Weight of Backfill (when submerged per ft of depth)		
			Silt & Clay (65 lb./ft <sup>3</sup> ) in air	Sand & Sandy soils (100 lb./ft <sup>3</sup> ) in air	Gravel & Gravelly Soils (115 lb./ft <sup>3</sup> ) in air
3½"	0.442	4.158	11.50	17.70	20.40
4"	0.481	5.532	13.20	20.30	23.30
4½"	0.792	6.892	14.82	22.79	26.21
5"	0.958	8.487	16.50	25.30	29.10
6"	1.051	12.252	19.75	30.39	34.95

OR

Conduit Size mm	Minimum Wt. of the Duct kg/m	Weight of Water displaced by the duct kg/m	Weight of Backfill (when submerged per m of depth)		
			Silt & Clay (1004 kg/m <sup>3</sup> ) in air	Sand & Sandy soils (1602 kg/m <sup>3</sup> ) in air	Gravel & Gravelly Soils (1852 kg/m <sup>3</sup> ) in air
89	0.658	6.188	17.11	26.34	30.36
102	0.716	8.233	19.64	30.21	34.67
114	1.178	10.255	22.05	33.91	39.00
127	1.426	12.630	24.55	37.65	43.30
152	1.564	18.231	29.39	45.22	52.01

To calculate the depth of cover required from the above table, use the maximum number of conduit in a vertical direction and multiply this by the difference between weight of water displaced and the weight of the conduit per foot as shown in the table above. This answer is the total buoyancy effect of a vertical column of conduit. Now select the type of backfill and from the table above, calculate the number of feet in depth required to hold the conduit submerged. We would suggest a safety factor of 2.

Calculate the weight of gravel needed to hold submerged a 2 x 2 array of 4" or 102 mm FRE® underwater conduits.

- a. Calculate weight of water displaced by duct (from table) w = 5.532 lb/ft or 8.2 kg/m
- b. Multiply weight of water displaced by number of vertical ducts in array w = 5.532 or 8.2 x 2 = 11.064 lb/ft or 16.5 kg/m
- c. Apply safety factor of 2 w = 11.064 or 16.5 x 2 = 22.13 lb/ft or 33 kg/m
- d. Determine weight of gravel by foot or meter of depth (from table) W = 23.30 lb/ft or 34.7 kg/m
- e. Verify if weight of gravel will suffice to hold ducts submerge 22.13 lb/ft or 33 kg/m < 23.30 lb/ft or 34.7 kg/m
- f. Conclusion: 3 ft or 1 m of gravel would suffice

Calculate the weight of sand needed to hold submerged a 3 x 3 array of 5" or 127 mm FRE® underwater conduits.

- |  |   |
|--|---|
| a. Calculate weight of water displaced by duct (from table)                | $w = 8.487 \text{ lb/ft or } 12.6 \text{ kg/m}$   |
| b. Multiply weight of water displaced by number of vertical ducts in array | $w = 8.487 \text{ or } 12.6 \times 3 = 25.461 \text{ lb/ft or } 37.9 \text{ kg/m}$      |
| c. Apply safety factor of 2  | $w = 25.461 \text{ or } 37.9 \times 2 = 50.922 \text{ lb/ft or } 75.8 \text{ kg/m}$     |
| d. Determine weight of sand by foot or meter of depth (from table)         | $W = 25.30 \text{ lb/ft or } 37.7 \text{ kg/m}$   |
| e. Verify if weight of sand will suffice to hold ducts submerged           | $50.92 \text{ lb/ft or } 75.8 \text{ kg/m} > 50.60 \text{ lb/ft or } 75.3 \text{ kg/m}$ |
| f. Conclusion: 2 feet or 0.6 meter of sand would not suffice               |   |
| g. Verify if weight of sand will suffice to hold ducts submerged           | $50.92 \text{ lb/ft or } 75.8 \text{ kg/m} < 75.90 \text{ lb/ft or } 113 \text{ kg/m}$  |
| h. Conclusion: 3 feet or 0.9 meter of sand would suffice                   |   |



## APPENDIX "B"

### **PULLING FRICTION & UPLIFT FORCE DUE TO PULLING ANGLE**

The actual coefficient of friction between the conduit and a river trench is approximately 0.5 to 0.7 however we suggest a value of 1.0 should be used. Assume that the bottom conduits only are in contact with the trench and that these bottom conduit have to carry the load of all conduit directly above. Use the maximum weight of the conduit when calculating the friction drag.

Conduit size	3½" or 89 mm	4" or 102 mm	4½" or 114 mm	5" or 127 mm	6" or 152 mm
Max. wt lb./ft.	0.609	0.695	1.093	1.226	1.449
kg/m	0.906	1.034	1.627	1.824	2.156

The following diagram, equations and Tables can be used to calculate the weight of steel sled to prevent lifting the sled out of the trench.

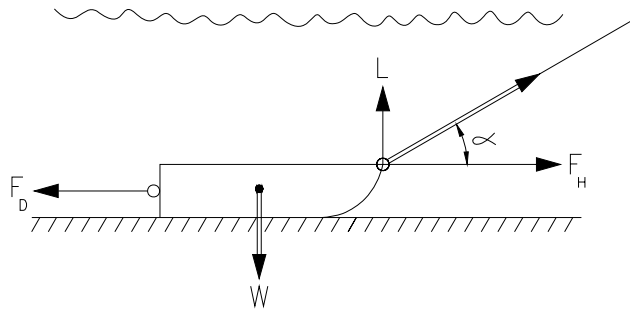

$F_H$  = Horizontal pull required to equal friction drag.

$F_D$  = Friction Drag

$W$  = Weight of sled in water

$L$  = Lift force if cable pull is not horizontal

$\alpha$  = Angle of pull

1. Weight of sled in water ( $W$ ) must equal or exceed lift force " $L$ "
2.  $F_D$  = Friction Drag Force = (Total weight of all duct) x (Coefficient of friction)  
= (Total weight) x (Coefficient = 1.00)
3. Lift Force =  $L = F_H \times \text{TAN } \alpha$  = Min. value of sled wt. in water

$\alpha$ = Angle of pull	0°	5°	10°	15°	20°	25°	30°	35°	40°	45°
TAN $\alpha$	0.000	0.087	0.176	0.268	0.364	0.466	0.577	0.700	0.839	1.000

$$\begin{array}{rcl}
 4. & \text{Weight sled in water (steel)} & = & W \\
 5. & \text{Weight of steel sled (out of water)} & = & \frac{W}{490 - 62.4} \times 490
 \end{array}$$

1 ft. <sup>3</sup> Steel	=	490 lb. or 2 392.2 kg/m <sup>3</sup>
1 ft. <sup>3</sup> Water	=	62.4 lb. or 304.6 kg/m <sup>3</sup>

APPENDIX "C"

**SLED DESIGN**

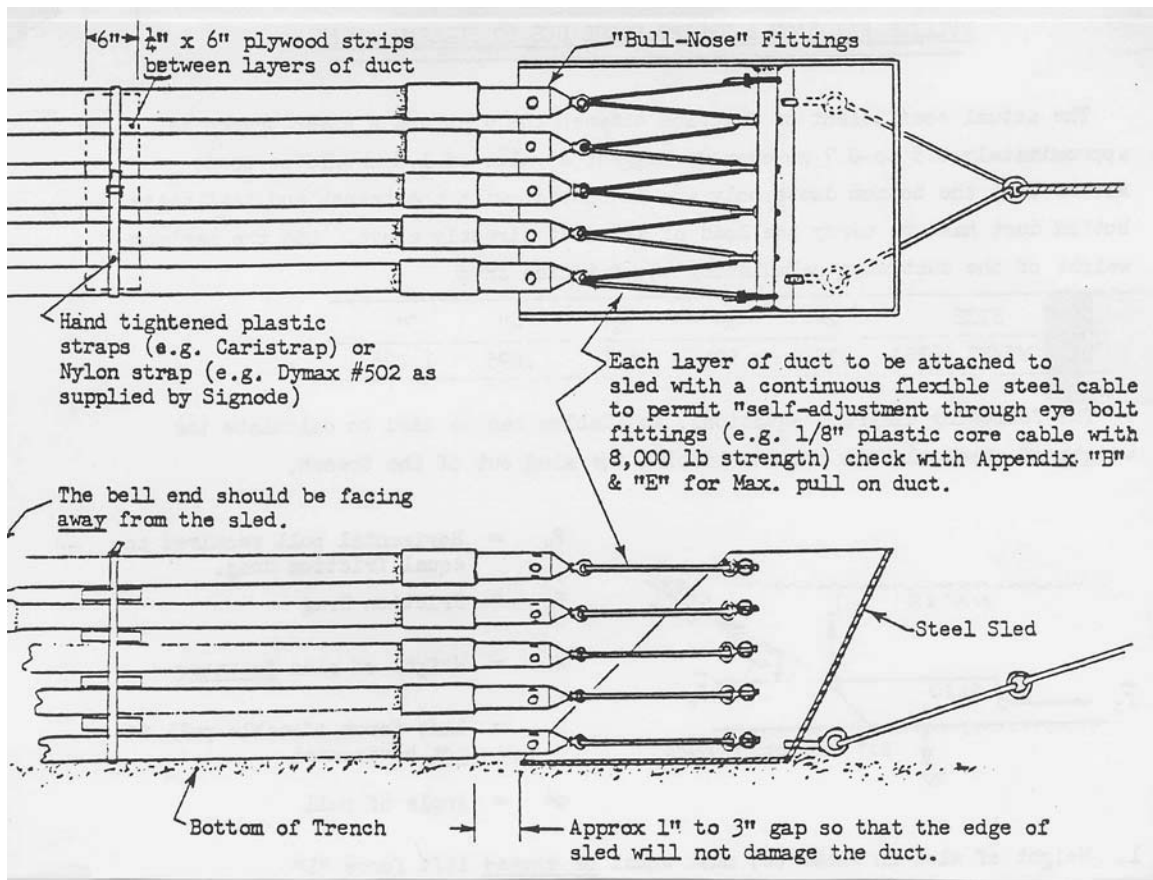

This document is the property of FRE Composites (2005) Inc. It shall not be used, reproduced, copied or transmitted to other persons without written authorization from FRE Composites (2005) Inc. - © 2005. All rights reserved, FRE Composites (2005) Inc.

APPENDIX "D"

**FLOODING SYSTEM**

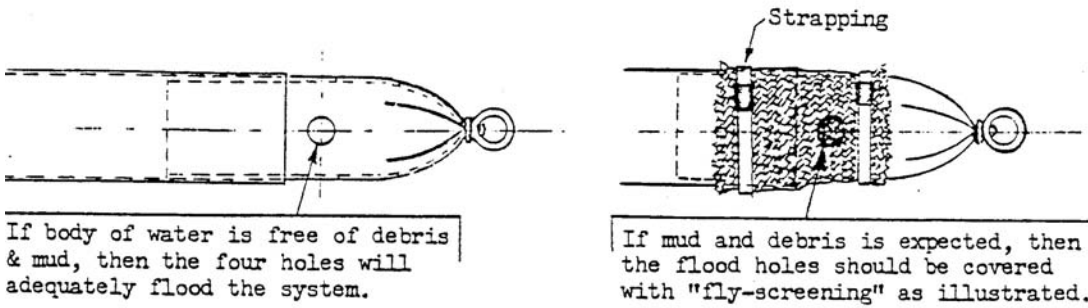

APPENDIX "E"

**MAXIMUM PULL ALLOWED**

In Appendix "B" we have shown how to obtain the value  $F_H$  which is the horizontal pull required to overcome the friction drag. This assumes that the bottom conduit must take the entire pull.

The axial strength of a properly "spliced" joint is equal to (or greater than) the axial strength of the conduit itself. The following table indicates the axial strength of the FRE<sup>®</sup> underwater conduit with such a joint.

Mechanically spliced conduit depends upon the "frictional grip" of the clamped split bell on the spigot. The following table shows the strength of such a joint.

Type of FRE Duct	SPliced JOINT	
	Load at failure Lb./Kg	Recommended Max Load Lb./Kg
3½" Helical Duct (underwater type)	5 200 lbs / 2 359 kg	2 600 lbs / 1 179 kg
4" Helical Duct (underwater type)	5 900 lbs / 2 676 kg	2 950 lbs / 1 338 kg
4½" Helical Duct (underwater type)	9 700 lbs / 4 400 kg	4 850 lbs / 2 200 kg
5" Helical Duct (underwater type)	10 800 lbs / 4 899 kg	5 400 lbs / 2 449 kg
6" Helical Duct (underwater type)	12 900 lbs / 5 851 kg	6 450 lbs / 2 926 kg

This document is the property of FRE Composites (2005) Inc. It shall not be used, reproduced, copied or transmitted to other persons without written authorization from FRE Composites (2005) Inc. - © 2005. All rights reserved, FRE Composites (2005) Inc.

## APPENDIX "F"

### **STEEL STRAPPING**

Black painted (1) Size		Average Breaking Strength in lb.	Specifications fact per pound	Average Coil Weight (pounds) Oscillated Wound	Galvanized (2)		Tight Edge (3) No. 1 Flat	Stainless (4)		
Width	Thickness				Std.	Heavy		Type 302	Type 316	Type 317 ELC
½"	0.020	1150	29.41	100		X	X	X	X	X

X Indicates stock items.

### **STAINLESS SEALS**

Of type 302, 316 and 317 ELC Stainless Steel are available for use with comparable types of Stainless Strapping.

Strap Size	Seal Number	Type of Seal	Type of Joint	Seal Length	Net Weight 1000 Seals Pounds	Standard Pack	Type 302	Type 316	Type 317 ELC.
½"	44	Closed	Single Notch	¾"	5¾	500	X	X	X

### **POWERED TENSIONERS – Regular Duty, Pneumatic**

Model	Strapping Requirements	Description	Net Wt. (lb.)	Sealer	Strap Width Gauge	Dispenser
B1K4	Curved	Rotary/push	3½	C2 Series	3/8" & ½", .012" to .025" 5/8" X ¾", .012" to .025"	D1AO, E33EO or E29AO

### **MANUAL SEALERS – Regular Duty**

Type of joint	Strap width- gauge	Model	Net wt. lb.	Handle Type	Seals	Seals per joint	Sealer strokes per seal
Single Up- Notch	½", .010" to .023"	C2A4	2½	A	44, 44PB	1	1

APPENDIX "G"

**BULL-NOSE FITTING**

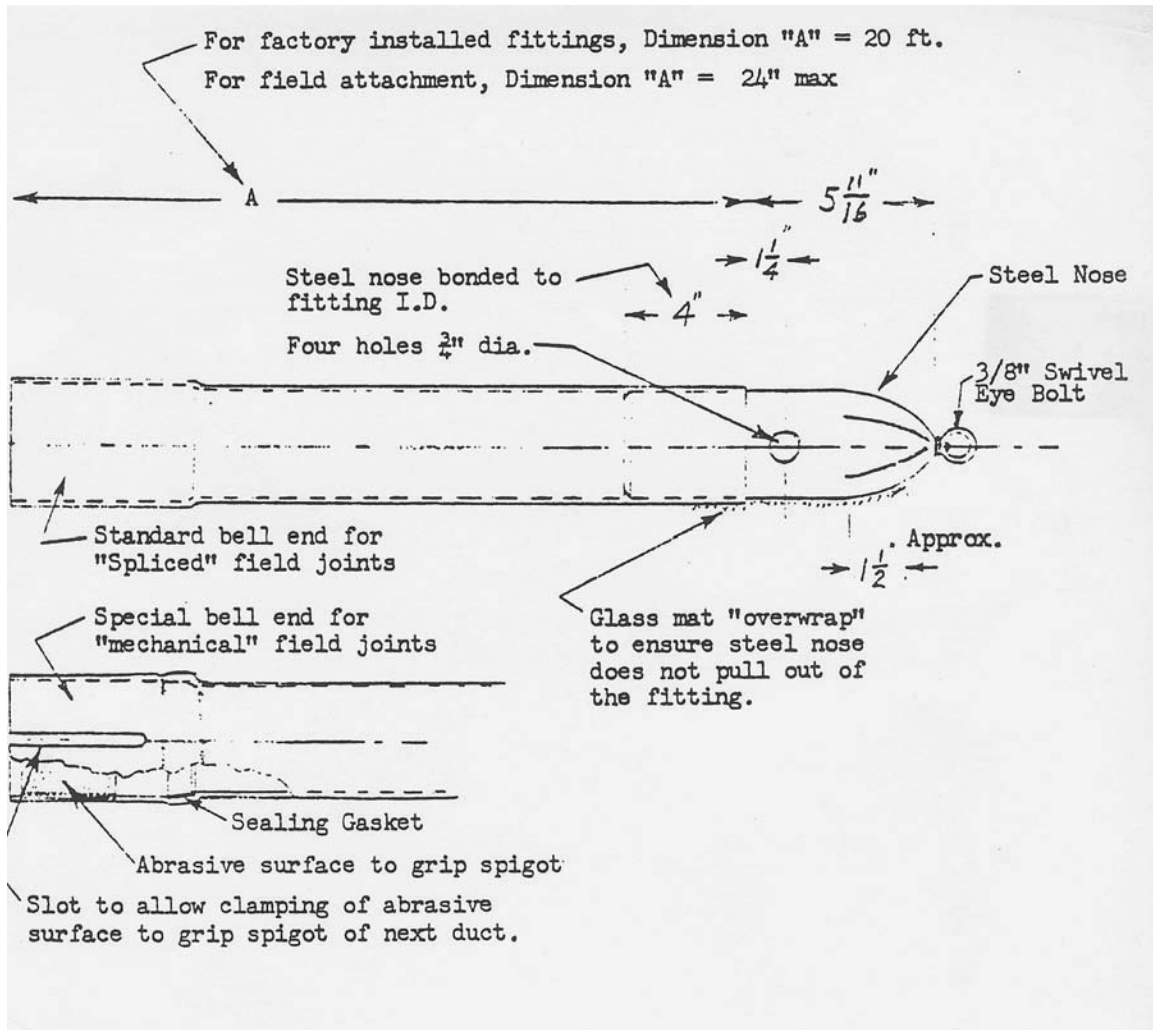

This document is the property of FRE Composites (2005) Inc. It shall not be used, reproduced, copied or transmitted to other persons without written authorization from FRE Composites (2005) Inc. - © 2005. All rights reserved, FRE Composites (2005) Inc.



## **INSTRUCTIONS FOR FRE® UNDERWATER CROSSING**

### **INTRODUCTION**

The following instructions regarding installation of underwater conduit are of a general nature and apply to all underwater installations. For additional comments, FRE Composites recommends that a drawing or sketch be provided describing the proposed installation.

### **LAYOUT**

In the plan view of the crossing the conduit must cross the body of water in a straight line. Gentle curves are permitted in the vertical plane allowing the conduit to emerge out of the water onto the shore. These curves must be limited to the minimum radius shown in Table No. 1.

TABLE 1.

SIZE		RADIUS AT FAILURE	RECOMMENDED MIN. RADIUS
In.	mm		
3½"	89	Estimate less than 20 ft. or 6.1 m	40 ft. or 12.2 m
4"	102	Estimate less than 25 ft. or 7.6 m	50 ft. or 15.2 m
4½"	114	Estimate less than 30 ft. or 9.2 m	75 ft. or 22.9 m
5"	127	Estimate less than 30 ft. or 9.2 m	75 ft. or 22.9 m
6"	152	Estimate less than 40 ft. or 12.2 m	100 ft. or 30.5 m

Simultaneously bending a conduit in two (2) planes (such as horizontal and vertical) should not be tolerated underwater and if possible should also be avoided on land. FRE Composites should be consulted before attempting compound bending.

### **TRENCHING**

The underwater trench must be in a straight line (plan view). The excavated material should be piled beside the trench on the downstream side to reduce the tendency of the flowing water filling in the trench with silt before the conduit can be placed. The trench must be deep enough so that when the conduit is in place and covered with back fill it will not become buoyant when the water is removed from all the conduit. Appendix A of this report can be used to calculate the buoyancy effect of the air filled conduit and the depth of the fill required to counteract this buoyancy.

### **TRENCH PREPARATION**

The bed of the trench must be free of hollows and humps because these can introduce regions of high stress in the conduit. If the river bed consists of soft earth, clay or mud then a minimum of 8 in. or 203 mm of gravel (¾" or 19.05 mm maximum size) must be placed in the bottom of the



trench. Similarly if the bottom is very rocky or contains large stones, then a minimum of 6 in. or 152 mm of gravel must be placed in the bottom of the trench. If the river bed is stable and consists of gravel or sand, then no extra gravel need be placed in the trench. In all cases the bottom of the trench must be smooth before the conduit is installed. One technique of doing this is to pull a steel sled or scraper across the river. One type of steel sled is shown in Appendix C and Appendix D. It is further recommended that a diver inspect the trench immediately prior to pulling the conduit. In some cases it is advisable for the diver to follow the sled during the pulling operation.

## **SPLICE KIT METHOD**

The field "splice" method of joint conduit requires the conduit surface and the glass mat to be free of moisture. The presence of moisture will inhibit the cure and reduces the strength. A minimal temperature of 70°F or 21°C is necessary for curing. This means that in cold weather some provision must be made to heat the splice joint till cured. This method is a little more "messy" than the mechanical method, however this method is positively watertight. The joint can be tested by tapping the splice with fingernails for hardness .

The following instructions apply to the use of "Splice Kit" to join conduit sections. The standard splice kit will have sufficient resin, catalyst, and glass mat to make a specified number of joints with sufficient working gloves, paint rollers, etc... for the project.

The following steps should be carefully followed when making field splice joints:

1. The outer surface of the spigot end must be clean, dry and roughened. The surface will be sanded at the factory however during installation this should be double checked without sanding of the surface the bond strength is reduced.
2. Fully assemble the spigots into the bell fittings .
3. All persons who will be working with the resin should apply barrier cream on their hands and wrists for skin protection.
4. Mix the two (2) components together (Part B into Part A) and stir well for one (1) minute. Keep the mixed resin out of the direct sunlight. Do not heat unless conditions are cold. Keep the mixture at room temperature or less.
5. Wear the vinyl coated gloves when applying resin to the glass.
6. Place one length of glass mat (precut) on a dry and clean piece of cardboard, masonite, wood or metal that is at least 6 in. or 152 mm larger than the glass mat strips.
7. Pour a little resin (zig zag manner on top of the glass mat as shown).

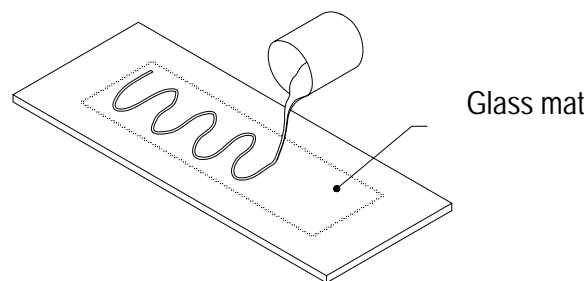

8. With the small paint roller, roll out the resin to wet the entire glass mat thoroughly.
9. Fold the long edge over 2 in. or 51 mm as shown. Folded edge should have a little extra resin.

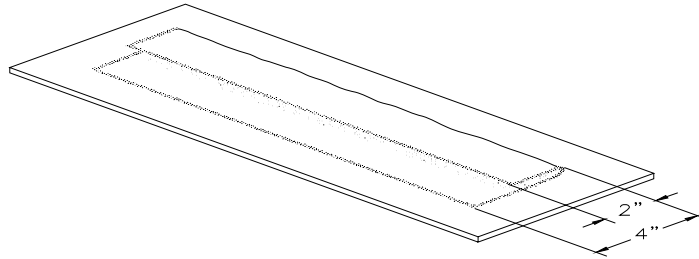

10. This resin impregnated and folded strip of chopped glass mat is now wrapped around the spigot with the folded edge butting against the end of the bell as shown. The ends of this strip will overlap somewhat and this is desirable.

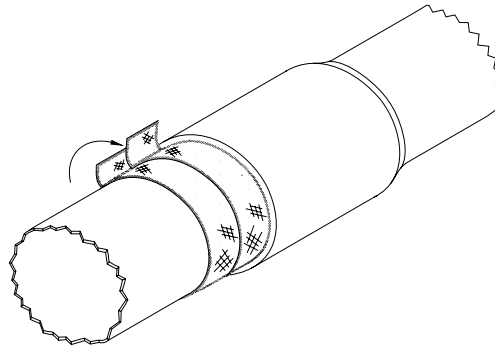

11. Remove air bubbles from this wrap-around strip by rolling the resin saturated paint roller over the surface.
12. The next three (3) pieces of glass mat are impregnated in sequence with resin in a similar manner but these are NOT folded.
13. The first strip is wrapped around the joint with one edge on the spigot, about four (4) inches away from the edge of the bell and overlapping the bell by about 2 in. or 51 mm as per diagram below. Always remove the air bubbles as mentioned above before applying the next layer.
14. The next strip is wrapped around the joint so that about 3 in. or 76 mm of glass mat is on the bell and 3 in. or 76 mm on the spigot.
15. The last strip is wrapped around the joint so that about 2 in. or 51 mm is on the spigot and 4 in. or 102 mm on the bell. In this manner the strips of glass mat are staggered and yet each layer covers the joint for strength.

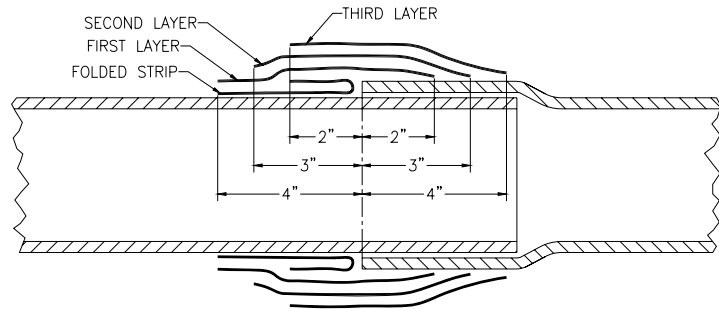

16. After the air bubbles have been removed as described, apply heat to the joint for speedy curing.
17. Proceed to the next splice while the first splice is curing.
18. Test the spliced joint, before removing heat, for completeness of cure by tapping it with the fingernails. The joint must be hard before pulling or removal of heat.

### ***BULL-NOSE FITTINGS***

A fitting called 'bull nose fitting' (to facilitate attachment of the conduit to the pulling cable) is shown in Appendix G. The end opposite the "eye" bolt is a "bell end", and this end is mechanically clamped over the spigot end of the conduit or joined with a splice kit. (These can also be factory installed). The pulling cable is attached to the swivel "eye" bolt. The purpose of the holes drilled in the sides of the metal part is to permit water to flood the interior of the conduit to prevent floatation of the conduit bundle. If the river is "muddy" it would be necessary to wrap fly screening around the fitting to cover these holes and keep out mud and debris. (Appendix "D").

### ***SLED DESIGN***

The purpose of the sled is to provide a means of transferring the pull from a single cable to each conduit in the conduit bundle. This sled must be heavy enough to avoid it being lifted out of the trench during the pulling operation. In Appendix "B" we have shown the method of calculating the up-lift force on the sled. This up-lift action is determined by the angle of the cable which is pulling the sled, the weight of the sled and the frictional drag of the conduit as it is pulled across the river. A suggested design is shown in Appendix "C" which also indicates the method of connecting the conduit to the sled. Provision must be provided for the conduit to slightly shift past each other. (See Appendix "C" and "D" ). The plywood spacers and loose strapping provides for this motion.



## ***CONDUIT BUNDLING***

Preassembled conduit must not be bundled together until just before they enter the water. Long lengths of conduit can be pulled along the ground, providing the conduit are guided in separate “channels” consisting of steel pipe or steel rods driven into the ground vertically. In this manner, the conduit can be snaked around curves and bends on the ground providing the minimum radius is not violated. Strapping application should be performed as close to the water as possible to tie the conduit into a somewhat loose bundle. Plywood strips are used between layers of conduit in order to allow lengthwise adjustments of the conduit during pulling. Care must be taken that the strapping is not too tight. (Some axial adjustment is necessary between the conduit during the pulling operation). The weight of the conduit in the water will be considerably reduced and therefore the abrasive action of gravel on the straps will be minimized in the water. The first strap should be at least 6 ft. or 1.8 m from the end of the conduit which is attached to the sled. It is recommended that subsequent strapping be located about every 10 ft. or 3 m.

## ***PULLING THE CONDUIT INTO POSITION***

The conduit must flood as it enters the water to prevent the conduit floating to the surface. The holes in the “bull nose” fittings provides for this. It is imperative that the conduit is not subjected to a jerking action during the pull into the trench. A slow steady pull of about 1 ft. or 0.3 m per second is preferred. The pulling speed must be slowed if the conduit start to become buoyant to let the water flood the conduit. The information in Appendix “B” will help you determine the magnitude of the pull to be expected. It must be remembered that the lower conduit will experience the greatest pull because the frictional drag takes place on the lower conduit. Appendix “E” outlines the maximum pull allowed.

## ***BACK FILLING THE TRENCH***

The original trench material can be used for back fill providing it is free of stones larger than 3 in. or 76 mm and does not consist of muck or clay. If larger stones are present or if the material consists of muck or clay, then the conduit bank should be covered with 6 in. or 152 mm of gravel before filling in with the original excavated material. The depth of back fill required can be determined from Appendix “A” .Do not use concrete blocks for local anchoring. This presents a danger of shearing the conduit if such anchoring material settles into the river bed (such as at a soft spot). If concrete is required, then a cap should be poured for the entire length.

## ***RESPONSIBILITY***

We recommend that the customer consult with FRE Composites regarding each installation.

The foregoing comments are to be considered as recommendations only. Factors such as flooding the system, sled design, trench layout, trench preparation, back filling, and assembly must be engineered by the customer and becomes the responsibility of the customer.



FRE Composites warrants the FRE® conduit against defects in material and workmanship under normal use and service, their obligation being limited to replacing or repairing any conduit found defective in material or workmanship.





75 WALES STREET  
ST-ANDRE-D'ARGENTUILL (QUEBEC)  
CANADA J0V 1X0  
TELEPHONE: +1 450 537-3311  
FAX: +1 450 537-3415  
TOLL FREE: 888 849-9909

**FRE**  
COMPOSITES®

[WWW.FRECOMPOSITES.COM](http://WWW.FRECOMPOSITES.COM)



60 GREENHORN DRIVE  
PUEBLO CO 81004  
TELEPHONE: +719-565-3311  
FAX: +719-564-3415  
TOLL FREE: 888 849-9909